

VacStar™

DENTAL VACUUM SYSTEM

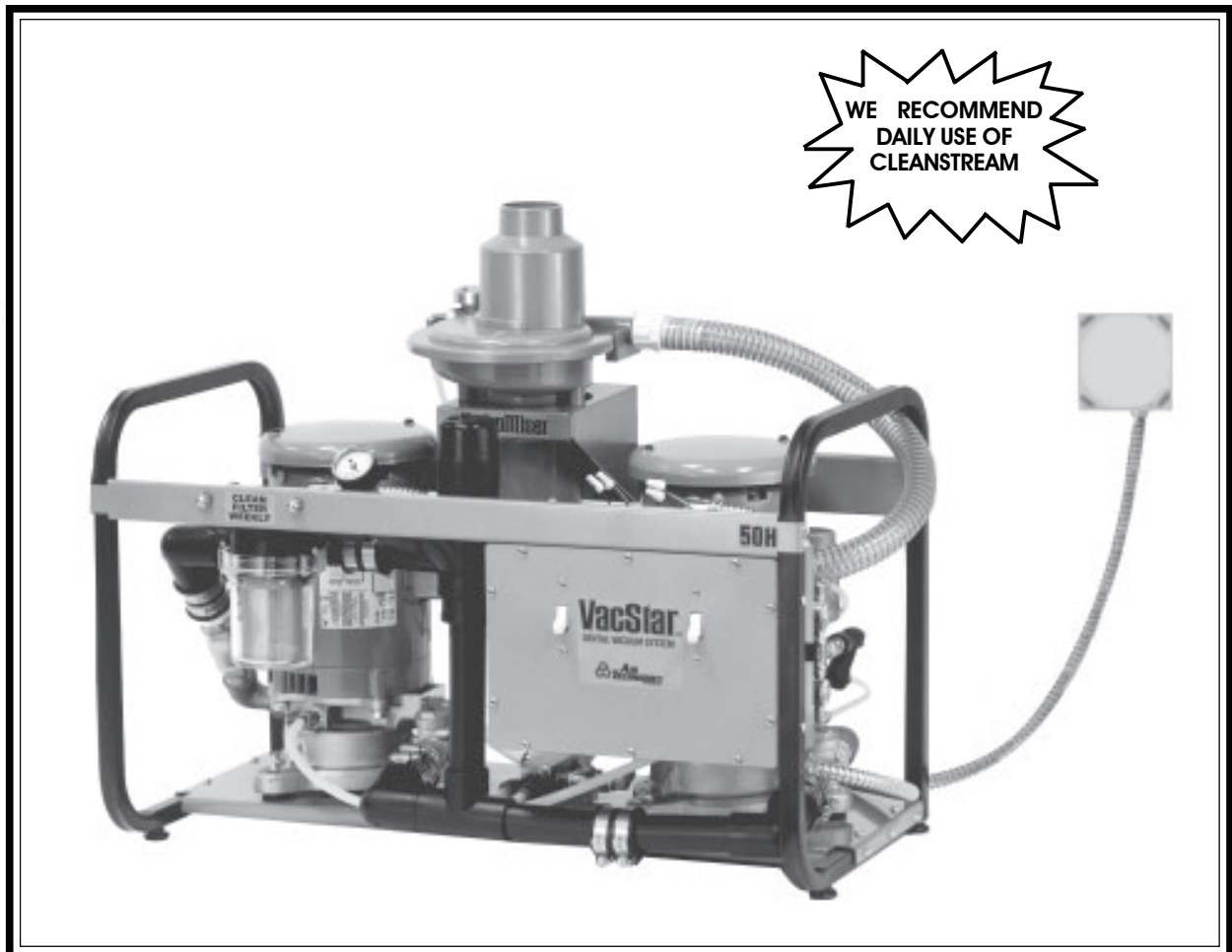

USER'S MANUAL

A6732  ISO 9001:2000
ISO 13485:2003

Air Techniques Inc.
Melville, NY

AIR
TECHNIQUES **ALLPRO**
INC. **IMAGING**

CONGRATULATIONS ON YOUR PURCHASE OF THE VACSTAR DENTAL VACUUM SYSTEM

Your VacStar has been engineered to deliver maximum air flow at the ideal vacuum level without creating traumatic suction pressure that could harm patients' delicate tissue. The VacStar is a water ring pump that produces consistent high-volume air flow, even with multiple users on-line. The balanced, corrosion free bronze impeller minimizes noise and a patented vacuum relief valve monitors and maintains constant uniform vacuum pressure. A capacitor-start type motor, with a highly reliable contactor and powerful transformer can be depended on to start every time. The VacStar is designed with everything accessible from the front, including the easy to clean solids collector.

If your VacStar comes with an integral HydroMiser, water consumption will be reduced by up to 75%. If not, a HydroMiser can be integrated into your VacStar at a later date. The HydroMiser separates the liquid and gas discharge from the operatories. The gases are vented out and the liquid and its particulates are directed down the drain. The clean water extracted during this separation process is directed back toward the VacStar where it is mixed with fresh water and then directed into the pump chamber to create vacuum. This efficient reuse of water reduces the VacStar's fresh water consumption.

Thousands of dentists have depended on the VacStar since 1987. Now that your practice has a VacStar, or a VacStar with the water saving HydroMiser, you too can depend on constant, uniform delivery of vacuum to your operatories and proven trouble-free operation.

TABLE OF CONTENTS

Sizing Guide	3
Maintenance	3, 4
Operating Information	4
Key Parts Identification	4, 5
Installation Information	6 - 8
Trouble Shooting	9
Product Specifications/Dimensions	10
Site Requirements	11
Optional Accessories	back cover
Replacement/Reorder	back cover

Choosing the correct size VacStar for your practice depends on the number of HVE (High Volume Evacuator) and SE (Saliva Ejector) users anticipated. To assure optimum vacuum, the vacuum demands should not exceed the number of HVE and SE users shown in the chart below:

RECOMMENDED NUMBER OF SIMULTANEOUS USERS

VacStar 20 HVE's + SE's	VacStar 40 HVE's + SE's	*VacStar 50 & 50H HVE's + SE's	*VacStar 80 & 80H HVE's + SE's
2 + 0	3 + 0	4 + 0	7 + 0
1 + 1	2 + 2	3 + 2	6 + 1
0 + 4	1 + 4	2 + 4	5 + 3
	0 + 6	1 + 5	4 + 4
			3 + 6
			2 + 8
<div style="border: 1px solid black; display: inline-block; padding: 2px;"> HVE - <i>High Volume Evacuator</i> SE - <i>Saliva Ejector</i> </div>			1 + 10
			0 + 13

* These combinations apply if both pumps are running together.
 If only one pump is running, use the Sizing Guide for VacStar 20 or 40.

MAINTENANCE

Daily Maintenance - Clean vacuum lines

To maintain the cleanliness of your VacStar, including all the vacuum lines and tubing in your dental system, we recommend the daily use of **CleanStream Evacuation System Cleaner**. (see back cover)

Weekly Maintenance - Clean solids collector

Caution: Solids collector may contain biologically hazardous material. Wear protective gloves.

Note: Clean the solids collector **DAILY** during the first week of operation and during the first week of Evacuation System Cleaner usage.

1. Use CleanStream Evacuation System Cleaner.
2. Turn off the power and water supply.
3. Unscrew the solids bowl (counter clock-wise) and remove the screen and gasket. Remove all the sediment build-up from the bowl, screen gasket and inside housing. Rinse thoroughly. See Fig.1.
4. Reassemble the bowl, screen and gasket and screw tightly back onto the solids collector body or replace screen and bowl with Solids Collector Replacement Kit PN 55094 or PN 55880.

Fig. 1



Important: A worn or missing gasket and/or failure to tightly screw the bowl to the solids collector body will cause poor suction due to air leakage.

DO NOT OPERATE THE VACSTAR WITHOUT THE SCREEN INSIDE THE FILTER BOWL.

MAINTENANCE

❑ In-Line Filter Kit

If a VacStar is replacing a previous vacuum pump, an optional In-Line Filter, located in front of the inlet manifold (see Key Parts) is recommended. This In-Line Filter is designed to collect larger quantities of particulates from the discharge BEFORE it flows into the vacuum pump.

Larger quantities of particulates may occur initially due to the VacStar's "pulling" power and to CleanStream Evacuation System Cleaner's ability to break down synthetic debris and proteinaceous deposits that build up in the vacuum lines. Check the filter daily and clean if required. In-Line Filter Kit for Single Vacuum Pumps #55078; for Twin Vacuum Pumps #55079.

OPERATING INFORMATION

❑ AT THE START OF THE DAY

Always TURN ON THE WATER before TURNING ON THE POWER.

- ❑ The VacStar may be turned on/off from a single, convenient location within the dental suite using a Remote Control Panel (See Optional Accessories).
- ❑ The vacuum level is factory preset at 10 In Hg (inches of mercury). This is the reading on the gauge when all HVE's (High Volume Evacuator) and SE's (Saliva Ejector) are CLOSED. Should this setting be too high for your needs, contact your dealer to readjust the setting.
- ❑ It is recommended that the system run continuously during the day. However, the VacStar can be turned off if suction is not required for a period of 15 minutes or longer.
- ❑ If one pump is being operated at a time, it is important to alternate pumps on an every other day schedule so that the pumps are used evenly.

❑ AT THE END OF THE DAY

Always TURN THE POWER OFF, then TURN THE WATER OFF.

KEY PARTS IDENTIFICATION - SINGLE UNITS

Fig. 2

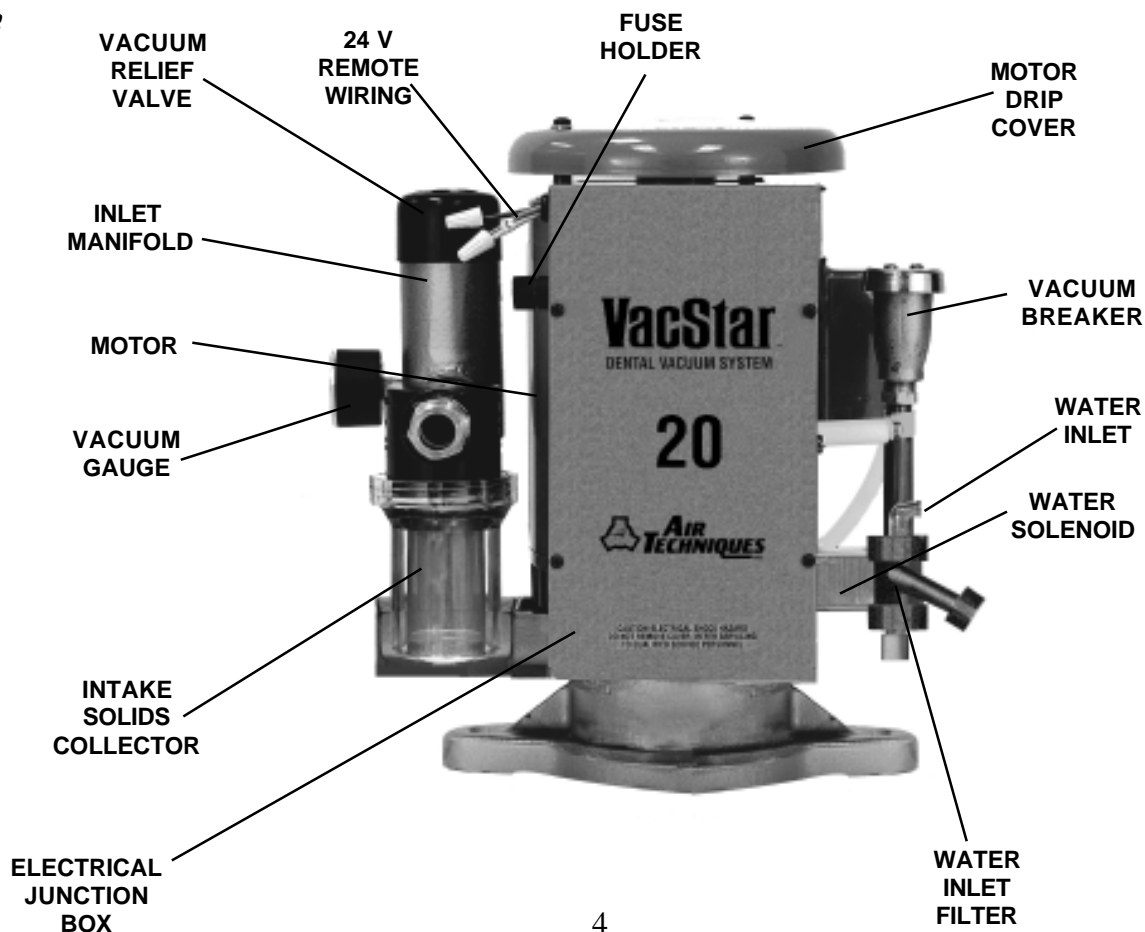

KEY PARTS IDENTIFICATION - TWIN UNITS

Fig. 3 Front View

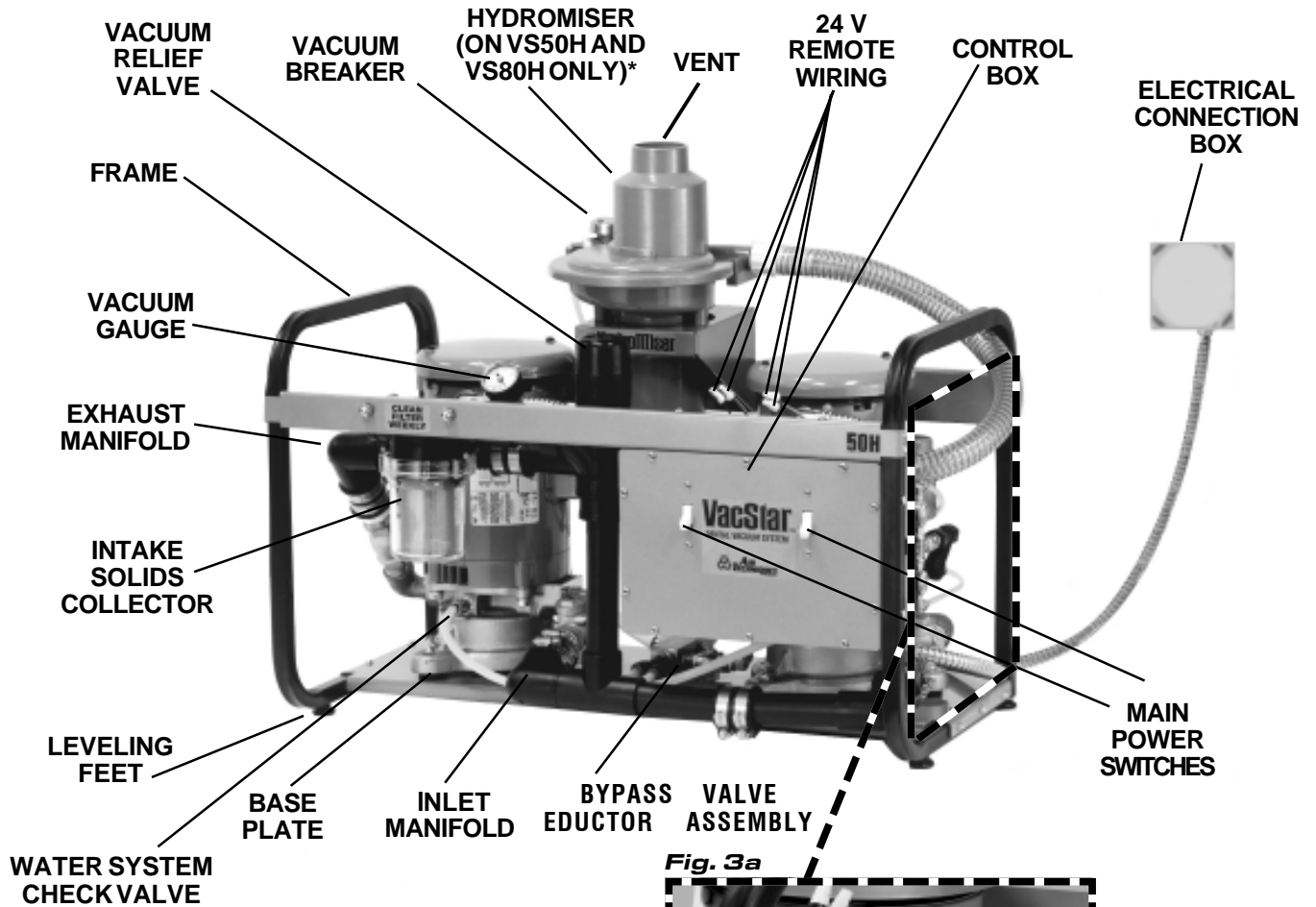

Fig. 3a

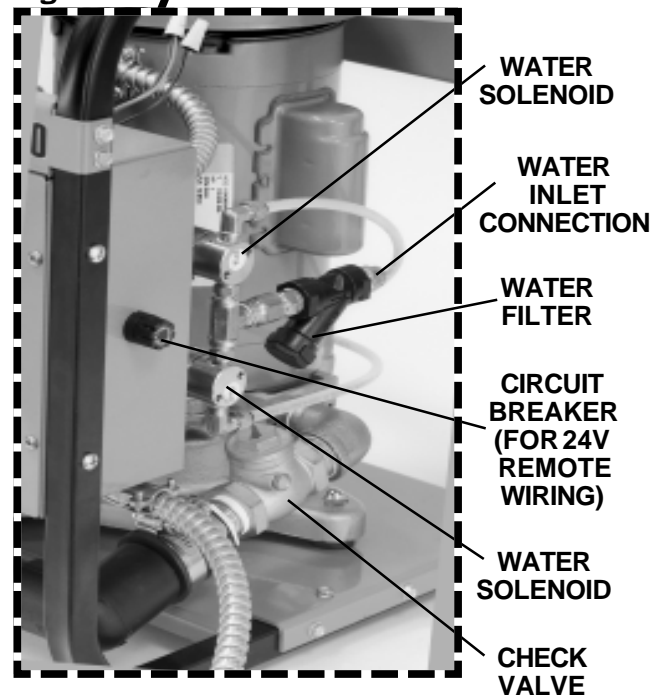
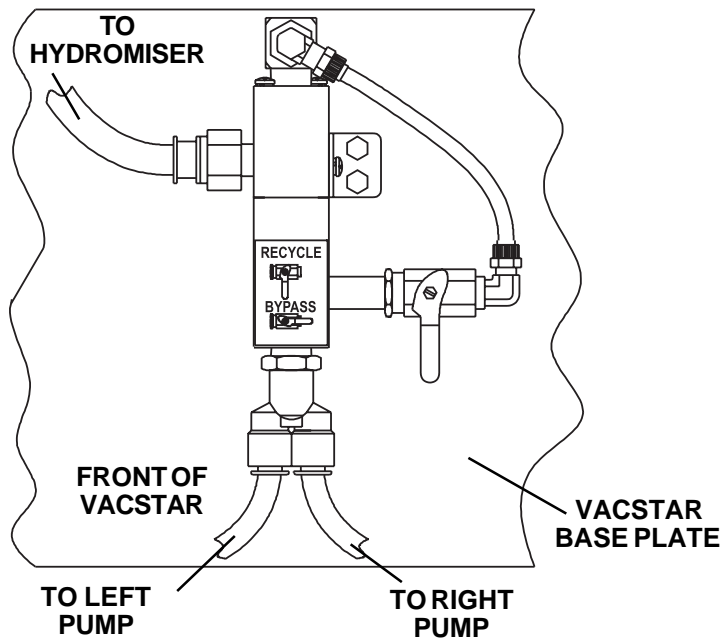

Fig. 4 Close up of Eductor Assembly



* VACSTAR 50H SHOWN - OTHER MODELS SIMILAR

INSTALLATION INFORMATION

❑ Plumbing (water) lines

- To assure that the VacStar provides optimum vacuum, incoming water pressure must be maintained between 20 and 100 psi.
- If heavy combinations of particulates exist in the incoming water, an in-line filter should be installed. (See Accessories/Options for the Remote Control Water Valve.) This will prevent the VacStar's water inlet filter from clogging too frequently.
- Incoming water temperature should be between 40°F and 75°F.
- Water connection location is shown in Fig. 2 and 3a (water inlet connection).

❑ Suction

- For VacStar 20 and 40, suction hose is connected at suction intake, found on intake solids collector assembly. See Fig. 2.
- For VacStar twin pump units, suction hose is connected at suction intake, found on intake solids collector assembly. See Fig. 3.

❑ Drain lines

- For VacStar 20 and 40 without a HydroMiser or an Air/Water Separator, see Fig. 5.
- For VacStars without a HydroMiser or an Air/Water Separator, the effluent should be discharged into an open drain or a closed vented drain. See Fig. 6.

Note: For VacStars without HydroMiser, the drain may be up to 36" above the unit.

Fig. 5 VacStar 20, 40 without a HydroMiser or Air/Water Separator

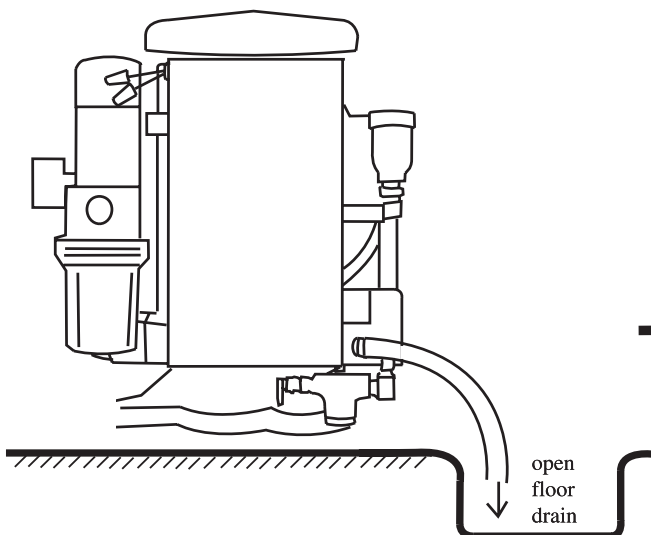
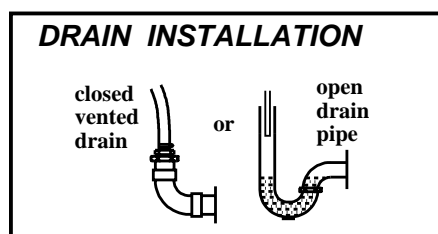
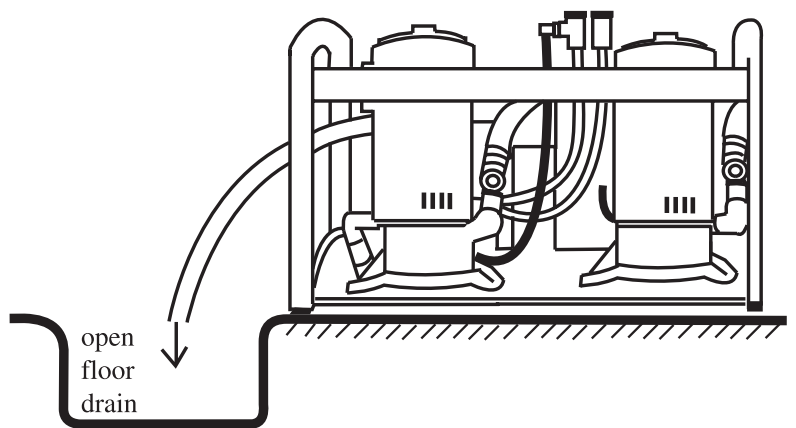

Fig. 6 VacStar 50, 80 without a HydroMiser or Air/Water Separator



INSTALLATION INFORMATION

- For VacStars with a HydroMiser (see Fig. 7) or an Air/Water Separator (see Fig. 8), gases should be vented out according to code. The waste water (with particulates) from the operatories can be discharged via an open drain or a closed vented drain.

Fig. 7 VacStar with built-in HydroMiser

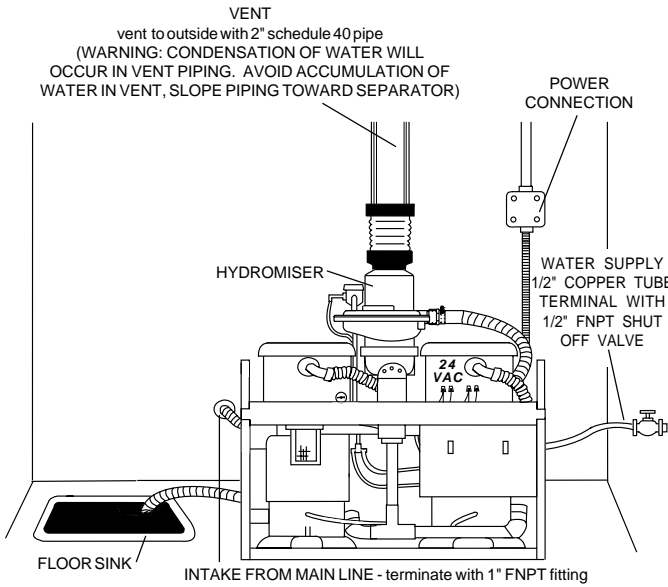
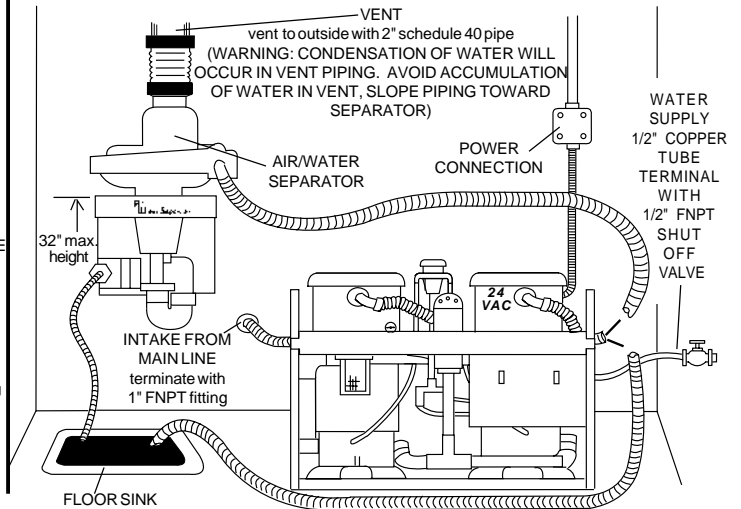
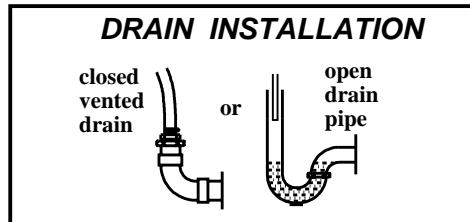

Fig. 8 VacStar with wall mounted Air/Water Separator



Note: VacStar 20, 40 installed in same manner



Wall-mounted HydroMiser

If the existing drain is higher than the HydroMiser outlet, the HydroMiser must be mounted so that its outlet is above the drain. The HydroMiser can be installed up to 36" above the base of the VacStar with the HydroMiser Wall Mount Kit (#55087).

IMPORTANT NOTE: ALL INSTALLATIONS

Ambient temperature for all VacStar installations should be 40° - 104°F (5° - 40°C).

The liquid drain from the HydroMiser or an Air/Water Separator must slope downward at least 1/4" for every 10 feet of run toward the drain. (Avoid local low sections, avoid creating traps in the line.)

Fig. 9 VacStar with wall mounted Hydromiser

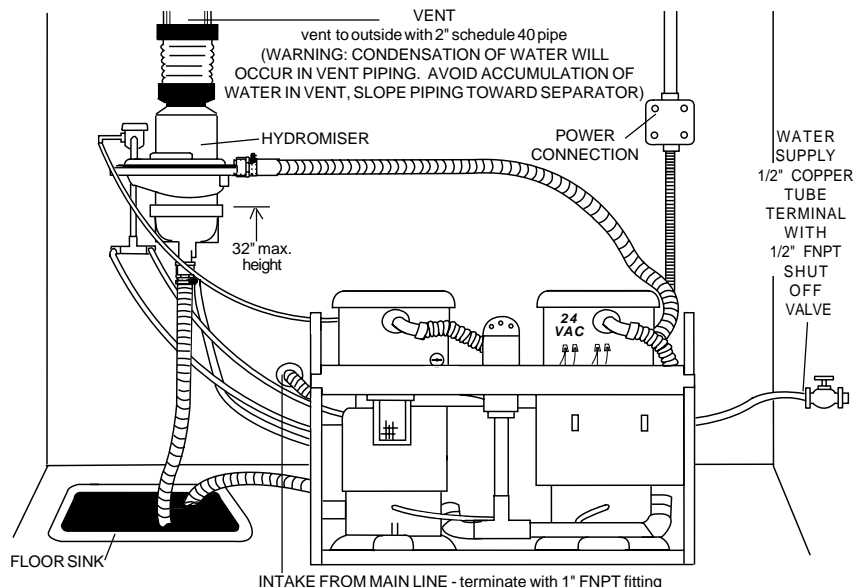

7 Note: VacStar 20, 40 installed in same manner

INSTALLATION INFORMATION

Electric

- If the voltage is below the minimum 105V or 205V, a Boost Transformer must be installed. (See Product Specifications/Dimensions)
- All VacStars must be wired directly from an electrical box that complies with local electrical codes to the VacStar's Electrical Connection Box . See Fig. 10 for VacStar 20, 40; Fig. 11 for VacStar 50, 50H, 80, 80H.

FIG. 10 VACSTAR ELECTRICAL JUNCTION BOX - INTERIOR VIEW VacStar 20, 40

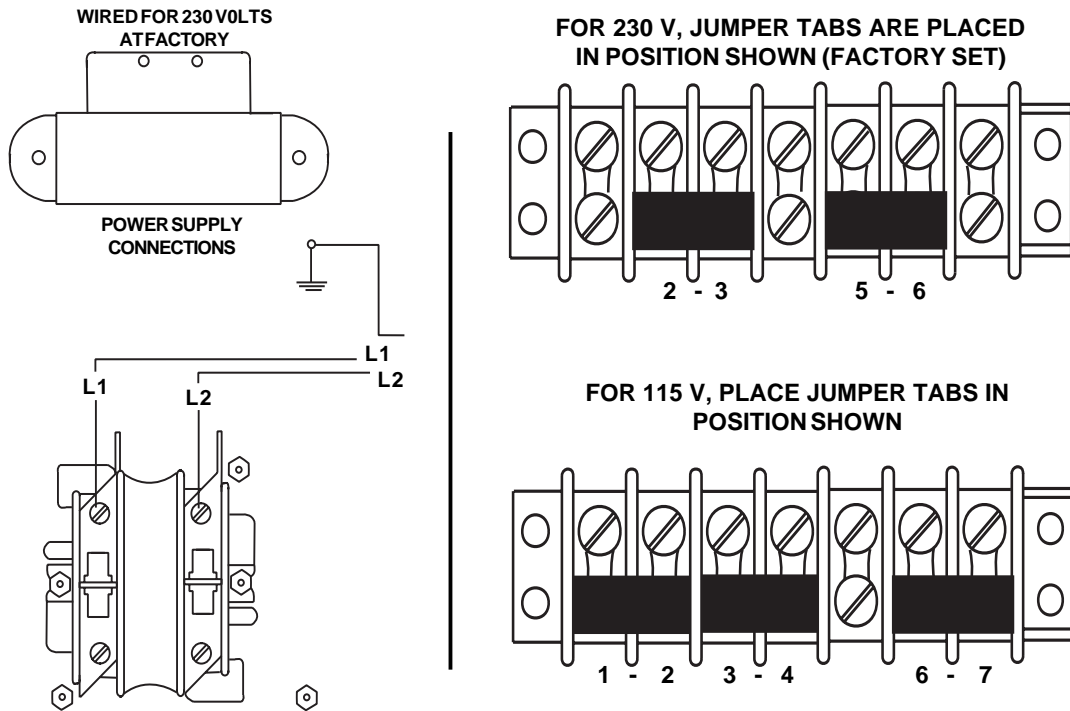
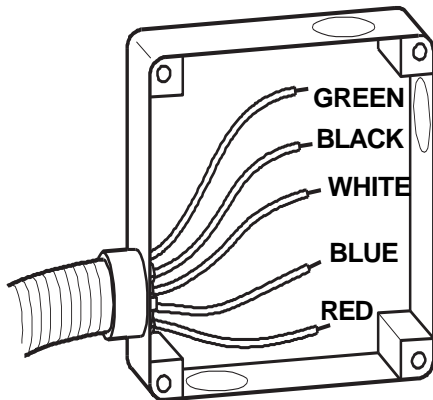

FIG. 11 VACSTAR ELECTRICAL CONNECTION BOX - VacStar 50, 50H, 80, 80H



DUAL CIRCUIT

PUMPS	POWER LEADS
RIGHT	(L1) BLACK (L2) WHITE
LEFT	(L1) RED (L2) BLUE

* For Single Circuit connect Black and Red wires together (L1) and White and Blue wires together (L2).

TROUBLE SHOOTING

PROBLEM	POSSIBLE CAUSE	POSSIBLE SOLUTIONS
1. Low suction.	<ul style="list-style-type: none"> a. Water filter or solids collector clogged. b. Check valves are stuck. c. Low water pressure. d. HydroMiser water recycler is clogged. e. HydroMiser clogged. f. Solenoids not operating. g. Restricted air exhaust 	<ul style="list-style-type: none"> a. Clean filter and/or collector. b. Use a system cleaner like CleanStream; turn vacuum on and off to free check valve. If valve remains stuck, call your authorized Air Techniques dealer for repair service. c. Raise water pressure. d. Open bypass valve to run VacStar. Call your authorized Air Techniques dealer for repair service. e. Call your authorized Air Techniques dealer for repair service. f. Call your authorized Air Techniques dealer for repair service. g. Check air exhaust pipe size to make sure it conforms to spec; check for and clear possible restrictions in air exhaust system.
2. No suction.	<ul style="list-style-type: none"> a. Pumps off. b. Pumps not running. c. Inlet check valves stuck closed. d. Water inlet filter and/or Solids collector clogged. e. Suction hose collapsed. f. Solenoids not operating. 	<ul style="list-style-type: none"> a. Turn pumps on. b. Call your authorized Air Techniques dealer for repair service. c. Call your authorized Air Techniques dealer for repair service. d. Clean filter. e. Hose needs to be replaced, call your authorized Air Techniques dealer for repair service. f. Call your authorized Air Techniques dealer for repair service.
3. Excessive suction.	<ul style="list-style-type: none"> a. Relief valve stuck closed. b. Relief valve filter clogged. 	<ul style="list-style-type: none"> a. Call your authorized Air Techniques dealer for repair service. b. Call your authorized Air Techniques dealer for repair service.
4. Pumps do not run.	<ul style="list-style-type: none"> a. Main switches off. b. Electrical problem. 	<ul style="list-style-type: none"> a. Turn main switches on. b. Call your authorized Air Techniques dealer for repair service.
5. Noisy Pumps.	<ul style="list-style-type: none"> a. Inadequate water supply. b. HydroMiser eductor clogged. c. Drain line collapsed. d. Solenoids not operating. 	<ul style="list-style-type: none"> a. Call plumber to improve water supply system. b. Call your authorized Air Techniques dealer for repair service. c. Hose needs to be replaced. Call your authorized Air Techniques dealer for repair service. d. Call your authorized Air Techniques dealer for repair service.

ALL INSTALLATIONS TO CONFORM TO LOCAL CODES

PRODUCT SPECIFICATIONS/DIMENSIONS

ELECTRICAL	VS 20	VS 40	VS 50	VS 50H	VS 80	VS 80H
Voltage Rating	*115/230	230	230	230	230	230
Voltage Min./Max.	*205/240 105/125	205/240	205/240	205/240	205/240	205/240
Full Load Amps	*16/8	13.4	16	16	26.8	26.8
WATER						
Inlet Water Pressure (PSI)	20 - 100	20 - 100	20 - 100	20 - 100	20 - 100	20 - 100
Flow Rate Per Pump (gal/min) w/HydroMiser	0.12	0.18	N/A	0.12	N/A	0.18
Flow Rate Per Pump (gal/min) w/o HydroMiser	0.50	0.75	0.50	N/A	0.75	N/A
Water Temperature (°F)	40 - 75	40 - 75	40 - 75	40 - 75	40 - 75	40 - 75
VACUUM LEVEL						
Preset at Factory (InHg)	10	10	10	10	10	10
SHIPPING WEIGHT (lbs)	68	85	160	170	200	210
DIMENSIONS in. (HxWxD)	14 x 11x 11	17 x 11 x 11	22 x 28 x 16	25 x 28 x 16	22 x 28 16	25 x 28 x 16

*VacStar 20 may be converted from 230 Volts to 115 Volts at installation site.

SITE REQUIREMENTS

ELECTRICAL	VS 20	VS 40	VS 50	VS 50H	VS 80	VS 80H
Min. Circuit Breaker Rating	20A	20A	30A	30A	2 ea. 20A or 1 ea. 40A	2 ea. 20A or 1 ea. 40A
Wire Size AWG (Min. Gauge)	12	12	10	10	2 ea. 12 or 1 ea. #8	2 ea. 12 or 1 ea. #8
*Boost Transformer	#67002(230V) #67500(115V)	#67002	#67002	#67002	#67002 2 ea.	#67002 2 ea.

PLUMBING	VS 20	VS 40	VS 50	VS 50H	VS 80	VS 80H
Min. CFM @ 0" Hg	16	22	32	32	44	44
Air Exhaust	2" schedule 40 pipe	2" schedule 40 pipe	2" schedule 40 pipe	2" schedule 40 pipe	2" schedule 40 pipe	2" schedule 40 pipe
Ambient Temperature	40° - 104°F (5° - 40°C)	40° - 104°F (5° - 40°C)	40° - 104°F (5° - 40°C)	40° - 104°F (5° - 40°C)	40° - 104°F (5° - 40°C)	40° - 104°F (5° - 40°C)
Overhead Plumbing						
Main Line Dia. Min./Max ID in inches	1 / 1½	1¼ / 2	1¼ / 1½	1¼ / 1½	1½ / 2	1½ / 2
End Fitting Max	1" FNPT	1" FNPT	1" FNPT	1" FNPT	1" FNPT	1" FNPT
Riser Diameter Overhead Main Line	½" ID	½" ID	½" ID	½" ID	½" ID	½" ID
Floor Plumbing						
Main Line Dia. Min./Max. ID in inches	1 / 1½	1¼ / 2	1¼ / 1½	1¼ / 1½	1½ / 2	1½ / 2
End Fitting Max	¾" FNPT	¾" FNPT	1" FNPT	1" FNPT	1" FNPT	1" FNPT
Branch Line Dia. Min./Max. ID in inches	¾ / 1½	1 / 1½	1 / 1½	1 / 1½	1 / 1½	1 / 1½

NOTE: Suction piping must slope at least a ¼" for each 10 feet of run towards the pump.

Use PVC Schedule 40 or Copper Type M.

* Use Boost Transformer only if voltage is expected to fall below 105/205 Volts during operation.

ALL INSTALLATIONS MUST CONFORM TO LOCAL CODES

ACCESSORIES/OPTIONS

DESCRIPTION	MODEL	PART NUMBER
HydroMiser Wall Mount Kit	VacStar 50H, 80H	55087
Remote Control Panels with 24V switches	VacStar 20, 40 VacStar 50, 50H, 80, 80H	53250 or 53251 53113 or 53149
Remote Control Water Valve, with filter	All VacStar Models	53020 (24V) - 3/4" pipe 53020-1 (115V) - 3/4" pipe 53170 (24V) - 1" pipe 53171 (115V) - 1" pipe
Boost Transformer	VacStar 20 VacStar 20, 40, 50, 80 VacStar 80, 80H	67500 (115V) 67002 (230V) 2 each 67002 (230V)
HydroMiser Kit	VacStar 20 VacStar 40 VacStar 50 VacStar 80	H-2 H-4 56041 56042
Air/Water Separator	VacStar 20, 40, 50, 80	55540
In-Line Filter Kit	VacStar 20, 40 VacStar 50, 50H, 80, 80H	55078 - 3/4" pipe 55079 - 1" pipe
CleanStream Evacuation System Cleaner	All VacStars	57660 Starter Kit 57640 1 Box of 32 Packets

REPLACEMENT/REORDER

DESCRIPTION	MODEL	PART NUMBER
Solids Collector	VacStar 20, 40	55880
Replacement Kit	VacStar 50, 50H, 80, 80H	55094

Air Techniques is a leading manufacturer of dental equipment from air compressors and vacuum systems to x-ray film processors, intraoral video cameras, and most recently air abrasion, rapid curing and bleaching and digital imaging systems. We have been manufacturing quality products for the dental professional since 1962.

ACCENT™	Provecta 70™	100 Plus	ScanX® DVM
ACCLAIM®	ScanX®	2010 Plus	ScanX® NDT
AirStar®	SealX-2™	Medscope	ScanX® 12 EV
A/T 2000® XR	STS™	Provecta V	ScanX® 14 PORTABLE
Peri-Pro®	VacStar™	ScanX® 12	ScanX® NDT PORTABLE
Guardian™ Amalgam Collector		ScanX® 14	

AIR **ALLPRO**
TECHNIQUES **IMAGING**
INC

www.airtechniques.com

1-800-AIR-TECH

(1-800-247-8324)