

A/T ScanX[®] Intraoral

P/N B3100, B3100A, B3100J, B3100T

DIGITAL IMAGING SYSTEMS Operator's Manual

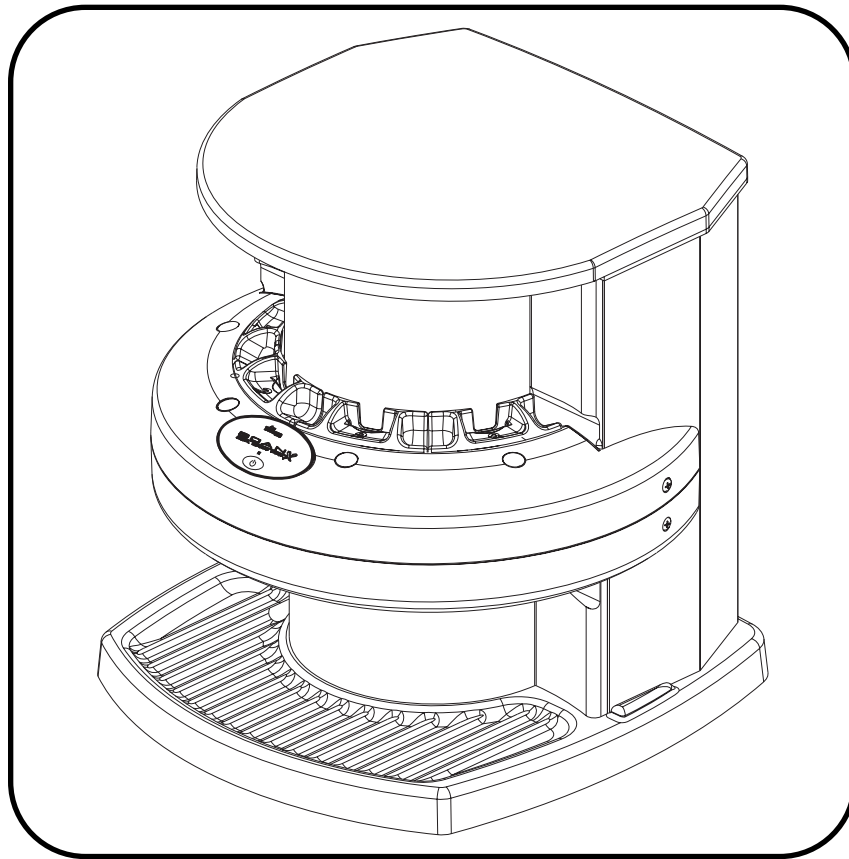

**AIR
TECHNIQUES**
INC.

 ALLPRO IMAGING

ISO
9001
ISO 13485
FDA-GMP COMPLIANT

TABLE OF CONTENTS

Introduction	.3
Warranty	.3
On-Line Warranty Registration	.3
Safety Instructions	.3
Purpose of this Manual	.6
System Description	.6
Unpacking the Unit	.6
Preinstallation Information	.7
Computer System Requirements	.7
Image Management Software Requirements	.7
Specifications	.8
Site Selection	.9
Abbreviations and Symbols	.9
Installation	.10
Accessories	.11
Imaging	.12
Intraoral Imaging	.12
Turning Off the ScanX System	.14
Maintenance Procedures	.15
Troubleshooting	.16
If You Need Assistance	.17

INTRODUCTION

Thank you for purchasing Air Techniques' A/T ScanX™ Intraoral Digital Imaging System (ScanX*). We have designed and manufactured the ScanX using state-of-the-art technology to give you many years of dependable service. To ensure that your ScanX gives you the highest level of service, review and follow the guidelines outlined in this Operator's Manual.

* This unit will be referred to as ScanX throughout the manual.

WARRANTY

This Air Techniques equipment is warranted to be free from defects in material and workmanship from the date of installation for a period of two years. This model of the ScanX is designed solely for use in a dental office environment for Intraoral imaging only and this warranty is not applicable to other applications.

Any item returned to our factory in Hicksville, New York, during the warranty period, through an authorized dealer, will be repaired or replaced at our option at no charge provided that our inspection shall indicate it to have been defective and that the system is returned to our factory in its shipping case. Dealer labor, shipping and handling charges are not covered by this warranty.

This warranty does not apply to damage due to shipping, misuse, careless handling or repairs by other than authorized service personnel. Air Techniques is not liable for indirect or consequential damage or loss of any nature in connection with this equipment.

This warranty is void if the ScanX is operated with any covers removed, or is used with other than intraoral imaging plates.

This warranty is in lieu of all other warranties expressed or implied. No representative or person is authorized to assume for us any liability in connection with the sale of our equipment.

Warranty - Phosphor Storage Plates

Air Techniques' Phosphor Storage Plates are designed for use with the ScanX. ScanX Phosphor Storage Plates will be replaced for a period of 30 days if defective in manufacturing or packaging.

ON-LINE WARRANTY REGISTRATION

Quickly and easily register your new ScanX on-line. Just have your product model and serial numbers available. Then go to the Air Techniques website, www.airtechniques.com, click the warranty link and complete the registration form. This on-line registration ensures a record for the warranty period and helps Air Techniques keep you informed of product updates and other valuable information.

SAFETY INSTRUCTIONS

ATTENTION USERS

The Manufacturing date code on serial number label of the ScanX is in the format: Month YYYY.

WARNING: To prevent fire or electrical shock, do not expose this appliance to rain or moisture. Use of the ScanX not in conformance with the instructions specified in this manual may result in permanent failure of the unit.



Alerts the user that important Operating and Maintenance instructions have been included with the unit. Read carefully to avoid any problems.



Warns the user that uninsulated voltage within the unit may be of sufficient magnitude to cause electric shock.



Indicates that the ScanX is a UL Listed product.



Indicates that models so labeled comply with the European Council Directives 73/23/EEC, 93/42/EEC, 89/336/EEC and 9368/EEC.

SAFETY INSTRUCTIONS



The ScanX is a Class I Laser Product [Class 1 Laser Product (IEC)]

This warning label identifies the A/T ScanX Intraoral P/N B3100, P/N B3100A and P/N B3100J as such products and describes the potential danger to humans in the event the product is opened during service. There is no laser radiation from this product when operated and maintained as instructed.

The Laser Product Accession Number is 0212282-00

DO NOT ATTEMPT INTERNAL SERVICE

The interior of the Main Assembly is only accessible by removing hardware with tools and should only be opened and serviced by an Authorized Air Techniques dealer Service Technician. Failure to heed this warning may result in equipment damage or personal injury, and will void any and all warranties.

Please contact your local authorized Air Techniques dealer for service information.

IMPORTANT INFORMATION

It is important that all personnel who use the ScanX read and understand this manual before operating the device. All personnel should follow all warnings and precautions for their safety and the safety of others around them.

Note: The Power Cord is the Mains disconnect device.

WARNING AND CAUTION STATEMENTS

In this manual, the following definitions apply for all WARNINGS and CAUTION Statements:

WARNINGS: Any operation, procedure or practice, which, if not strictly observed, may result in injury or long-term health hazards to personnel or patients.

CAUTIONS: Any operation, procedure or practice, which, if not strictly observed, may result in destruction of equipment or loss of treatment effectiveness or damage to equipment and PSP's.

SAFETY INSTRUCTIONS

WARNINGS

Only trained professionals should use this device. Federal law prohibits the sale of this device to individuals other than dental professionals. Use of this device, other than as described in this manual, may result in injury.

The ScanX contains a laser. The ScanX is a Class I [Class 1 (IEC)] Laser Product. Use of controls or adjustments or performance of procedures other than those specified herein may result in hazardous radiation exposure. The laser is on only during an active scan. Only a trained technician from an authorized Air Techniques dealer should remove a cover from the ScanX. Direct eye contact with the output beam from the laser may cause serious damage and possible blindness.

DANGER: Opening the ScanX by removing any covers or components makes it into a Class III b Laser Product. [Class 3B Laser Product (IEC)]

Do not open the ScanX to maintain it.

The ScanX contains no user serviceable parts. If there is a service problem, contact your authorized Air Techniques full service dental dealer.

Use only grounded electrical connections.

Use only the power supply and power cord provided with the unit.

Do not reuse the Barrier Envelopes.

Dispose of used Barrier Envelopes in accordance with all local regulations.

Imaging Plates are toxic.

Never place an intraoral PSP in a patient's mouth without first enclosing it in a sealed barrier envelope. The patient should be cautioned not to bite, chew, or swallow the enveloped PSP. If a patient swallows such a PSP, contact a physician immediately.

Do not use damaged PSP's.

Thoroughly rinse with running water any part of the body that comes in direct contact with the wet phosphor compound of the PSP.

Disposal of Phosphor Storage Plates.

Consult with your federal, national, state and local government, for rules and regulations on disposal of Phosphor Storage Plates.

CAUTIONS

Completely clean and erase PSP's before taking an x-ray exposure. (See **INTRAORAL IMAGING**)

Minimize exposing an x-ray exposed PSP to light.

Transfer the PSP to the Plate Guide slot quickly and with minimal light exposure.

Use care in handling PSP's - Avoid fingerprints and scratching

Refer to the booklet provided in the Phosphor Storage Plate package for further information on handling.

Use of Other Manufacturer's Imaging Plates

Intraoral PSP's from another manufacturer may be used as long as the specifications are the same as those for the ScanX PSP's.

PURPOSE OF THIS MANUAL

This manual provides the information necessary for the installation, operation and routine care and maintenance of the ScanX.

This manual is not to be used as a replacement for training in radiography.

For information regarding the computer system and imaging software, refer to the appropriate manuals provided by your hardware and software provider.

SYSTEM DESCRIPTION

The ScanX is a digital radiography system that utilizes reusable Phosphor Storage Plates (PSP) in place of X-ray film to produce diagnostic quality intraoral digital radiographs. The ScanX produces a digital image by scanning PSP's which have been exposed to X-ray. The ScanX system allows computer storage, processing, retrieval and display of the computed radiographic images utilizing user supplied software and computer .

UNPACKING THE UNIT

Each ScanX Digital Imaging System consists of the indicated model and accessory kit as listed below: (for ratings and identification see **SPECIFICATIONS**)

ScanX	Model	A/T ScanX Intraoral	A/T ScanX Intraoral	A/T ScanX Intraoral	A/T ScanX Intraoral
	P/N	B3100	B3100A	B3100J	B3100T
	CE Certified		Yes	Yes	Yes
<u>Accessory Kit containing:</u>					
Power Supply		73097	73097A	73097J	73097A
Power Cord		73096	74244	73096	73096
Computer Connector Cable		B3554	B3554A	B3554A	B3554A
Operator's Manual		B3029	B3029	*	B3029
Instruction, Drivers & Utilities		74226	74226	74226	74226
Plate Transfer Box		73470	73470	0	73470
	P/N	Qty.	Qty.	Qty.	Qty.
Phosphor Storage Plates (PSP)(Size 0, Qty. 2)	73445J-0	0	0	1	0
Phosphor Storage Plates (PSP)((Size 2, Qty. 4)	73445-2	5	5	0	5
Phosphor Storage Plates (PSP)((Size 2, Qty. 4)	73445J-2	0	0	2	0
Plate Guides (Sizes 0, 1, 3 Qty. 1 each; Size 2, Qty. 4)	73444	1	1	0	1
Plate Guides (Size 0, Qty. 1; Size 2, Qty. 3)	73444J	0	0	1	0
Barrier Envelopes (Size 0, Quantity 100)	73248-0	0	0	1	0
Barrier Envelopes (Size 2, Quantity 300)	73248-2	1	1	1	1
Drivers & Utilities Disk	74118	1	1	*	1
PDF Operator's Manual Disk	B3029PDF	1	1	*	1

* Operator's Manual, PDF Operator's Manual Disk and Drivers and Utilities Disk are provided separately.

The ScanX Digital Imaging System is shipped in one of two containers:

1. In a very special shipping case (P/N 9928-546) for which a deposit fee has been paid. This case may be returned to Air Techniques for a full refund of the fee using a Return Authorization (RA) number, or retained, without refund of the fee, to protect the ScanX in the event that it is to be transported or shipped in the future.
2. In a corrugated tri-wall carton (P/N B3050) for which no deposit fee has been paid. This carton should not be returned to Air Techniques, but may be retained to protect the ScanX in the event that it is to be transported or shipped in the future.

PREINSTALLATION INFORMATION

IMPORTANT: To operate the ScanX, it must be connected to a Computer System, and the computer must be loaded with Air Techniques Authorized Image Management Software. Neither the Computer System nor the Image Management Software is provided by Air Techniques. The Computer System and Image Management Software is provided by third party dealers.

COMPUTER SYSTEM REQUIREMENTS / RECOMMENDATIONS

The Computer System (computer, monitor, etc.) and any related peripheral or other equipment, supplied by the user, or a third party, must comply with the requirements for "Information Technology Equipment" (ITE) as specified in IEC 60950 (EN 60950).

The minimum computer system requirements necessary to operate the ScanX are listed below. Items listed with an asterisk (*) are required.

Operating System:	* Windows 2000 Professional for an Intel 32-bit processor with Service Pack 4 or later, or Windows XP Professional for an Intel 32-bit processor with Service Pack 1 and the KB B22603 update or later.
USB Port:	* Must be USB 1.1 or 2.0 or later
CPU:	2.8 GHz Pentium IV
RAM:	1 GB
Hard Drive:	120 GB
Monitor:	SVGA 17", 1024 x768 or higher resolution, contrast ratio 450:1, .22 dot pitch capability. For optimum viewing a CRT is recommended.
Video Display Adapter:	32 MB RAM
Peripherals:	* CD ROM Drive Standard Keyboard & Mouse Backup Device External Surge Protector Power supply backup
Image Management Software:	* Compatible software

IMAGE MANAGEMENT SOFTWARE REQUIREMENTS

Air Techniques Authorized Software is provided by third party dealers.

SPECIFICATIONS

ScanX SPECIFICATIONS

Electrical Requirements:

Supply Voltage:	100 to 240VAC +/- 10%, 50/60 Hz
Supply Current:	1 A maximum
Power Cord:	Air Techniques Authorized North American style 10 foot long or country-specific Hospital Grade power cord (P/N 73096).
Power Supply:	24 Volt Power Supply (Standard) P/N 73097 [GlobTek Model GT-21126-6024] or (Medical Grade) Power Supply P/N 73097A or 73097J [GlobTek Model GT-500148-24].

Physical Properties:

Dimensions:	D 15.13" x W 15.0" x H 15.5"
Weight:	43 lbs.

Environmental Conditions:

Unit in Operation

Temperature:	50°F to 105°F (10°C to 40°C)
Humidity:	5% to 95% RH (Non-condensing)
Heat emission	<70W

Storage and Transport

Temperature:	-21°F to 130°F (-29°C to 54°C)
Humidity:	5% - 95% (Non-condensing)

Compliance Data:

Laser Class:	Class I Laser Product (21 CFR 1040.10) Class 1 Laser Product (IEC 60825-1)
Laser Product Report Accession Number:	0212282-00
Installation Category:	I
Polution Degree:	2
User Servicable items:	Guides (Replacement) Power Supply (Replacement) Power Cord (Replacement) Computer Connector Cable (Replacement)

Resolution

Operating Mode	Resolution (LP/mm)		Pixel Size
	Vertical	Horizontal	(µm)
Intraoral Extra High	18+	12-14	20.83
Intraoral High	15	11-13	29.17
Intraoral Standard	10	10	50

SITE SELECTION

The ScanX may be located almost anywhere in the dental office. Follow these guidelines for optimum performance:

- Lighting conditions: You can set up the scanner in ordinary room light, however, direct sunlight and light fixture(s) above and near the ScanX producing more than 400 lux of light at the PSP guides must be avoided.
- Provide a stable, flat countertop large enough to hold the scanner, plus provide a working area.
- Locate the computer within 6 feet.
- Access to a standard grounded electric AC Mains outlet using the power cord provided, must be within 10 feet (power cords for international Mains outlets are available).

Please Note: The A/T ScanX Intraoral Digital Imaging System is designed to be installed by your authorized Air Techniques full-service dental dealer. The dealer or user must provide appropriate and compliant computer hardware and Air Techniques Authorized Imaging Software. Air Techniques does not provide computer hardware or software.

ABBREVIATIONS AND SYMBOLS

Abbreviations and symbols used in this manual are summarized below.

AC	alternating current	V	volts
DC	direct current	D	depth
Hz	hertz (cycles per second)	W	width, Watts
MHz	megahertz (millions of hertz)	H	height
cm	centimeter	lux	a measure of light intensity
PSP	phosphor storage plate (imaging plate)	°C	degree Celsius
Phosphor	a luminescent material	°F	degree Fahrenheit
CD-ROM	compact disc, read-only memory	RH	relative humidity
LP/mm	line pairs per mm	UL	Underwriters Laboratories
CPU	central processing unit (your computer)	PN	part number
IEC	International Electro-technical Commission	USB	Universal Serial Bus
CFR	Code of Federal Regulations	"	inch
FDA	Food and Drug Administration	A	ampere(s)
SVGA	Super Video Graphics Array	lbs.	pounds
RAM	random access memory	mm	millimeter
MB	megabytes		ON/OFF switch
GB	gigabytes	a	image orientation symbol on Air Techniques PSP's
IMS	Image Management Software [also referred to as Patient Management Software (PMS)]	YYYY	date (4 digit year)

INSTALLATION

HARDWARE SETUP AND CONNECTIONS

1. Select a location that meets the SITE SELECTION guidelines.
2. Set up the computer and monitor according to the manufacturer's recommendations.
3. Connect system components as illustrated in Figure 1 below and in accordance with specifications. Connect the 24V Power Supply to the ScanX prior to plugging the line cord into the Mains outlet.
4. Turn ON the power to the monitor and computer.
5. Turn ON the power to the scanner by pressing the membrane switch on the front of the scanner. The green light above the switch will illuminate.

Air Techniques Authorized Imaging Software, supplied by the dealer or other company, must be installed on the computer in order to operate the ScanX.

During operation track indicator lights are green when the configuration has been loaded, indicating that PSP's can be fed. They turn yellow or red when PSP's are being scanned. Additional PSP's should not be fed until lights turn green again. If all four lights stay yellow or red an error condition exists. Contact your authorized dealer.

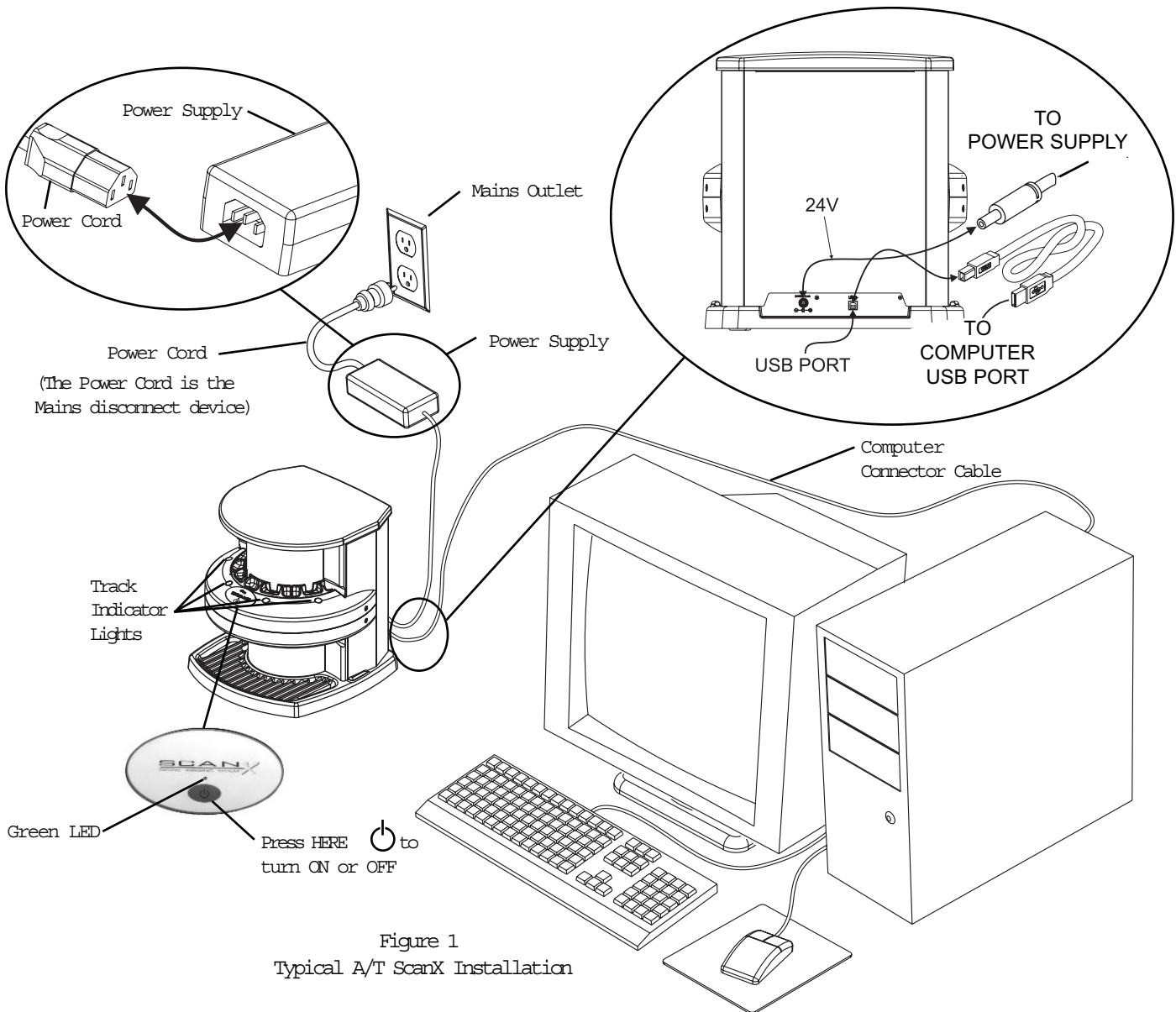

Figure 1
Typical A/T ScanX Installation

ACCESSORIES

COMPONENTS AVAILABLE FROM AIR TECHNIQUES

The following is a list of optional accessories available for purchase from your authorized Air Techniques dealer:
(For ratings and identification see Specifications)

Description	Quantity	Part Number	"J" Options
<i>A/T ScanX Eraser</i>	1	73800	
<i>Intraoral Plate Guides</i>			
Size 0	1	73566-0	
Size 1	1	73566-1	
Size 2	1	73566-2	
Size 3	1	73566-3	
<i>Intraoral Phosphor Storage Plates</i>			
			<i>No "a"</i>
Size 0	2 per package	73445-0	73445J-0
Size 1	2 per package	73445-1	73445J-1
Size 2	4 per package	73445-2	73445J-2
Size 3	2 per package	73445-3	73445J-3
Size 4	1 per package	73445-4	73445J-4
<i>Intraoral Barrier Envelopes</i>			
Size 0	100 per package	73248-0	
Size 1	100 per package	73248-1	
Size 2	300 per package	73248-2	
Size 3	100 per package	73248-3	
Size 4	50 per package	73248-4	
<i>Plate Transfer Box</i>	1	73470	
<i>Power Supply</i>	1	73097 or 73097A	73097J
<i>Power Cord</i>	1	73096 or 74224	
<i>Computer Connector Cable</i>	1	B3554 or B3554A	

COMPONENTS SUPPLIED BY USER

A compliant computer system, i.e. the CPU, monitor and peripherals
(see **PREINSTALLATION INFORMATION**).

Air Techniques Authorized Imaging Software provided by third party dealer.

IMAGING

Prior to reviewing the Intraoral Imaging sections on the following pages, note the configuration of the Phosphor Storage Plates in Figure 2.

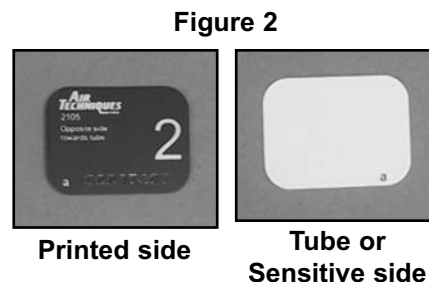

INTRAORAL IMAGING

PREPARING INTRAORAL PLATES

Erase the Plate

Phosphor Storage Plates (PSP) should be used (i.e., exposed and scanned) within 24 hours of erasure.

We recommend the use of the A/T ScanX Eraser (PN 73800), which assures complete erasing in approximately 35 seconds.

An alternate, but not recommended, way to erase the PSP is to use a view box. Place the PSP, tube side down, on an illuminated view box. Since view box light intensity is variable, you will have to experiment to determine the proper time for complete erasure. Use care not to scratch the PSP.

Package the Plate

Insert the erased PSP into the Barrier Envelope so the printed side of the PSP is visible through the transparent side of the envelope. Peel off the adhesive strip and seal the envelope. See Figures 3a - 3c below.



Figure 3a

Insert the PSP.



Figure 3b

Peel off the adhesive strip.



Figure 3c

Seal the Barrier Envelope.

The erased intraoral PSP in the sealed Barrier Envelope can then be placed into the patient's mouth. Make sure the opaque side of the Barrier Envelope is facing the tooth. Wear gloves and protective attire.

Take an X-Ray Image

The packaged PSP may be positioned exactly as you would use x-ray film. The orientation letter "a", printed on the PSP, may be used for reference as you would use the dot on an intraoral x-ray film. In addition, a backwards "a" (i.e. "ᵃ"), appearing in an image, is an indication that the image has been flipped. Note: If using holders with alligator clips, it is advisable to file down the points to avoid puncturing the Barrier Envelope. It is important to take care not to puncture the Barrier Envelope or damage the PSP.

The x-ray dose may typically be reduced by 80 - 85% of that required for D-speed intraoral film (depending on x-ray system used; the actual x-ray dose should be determined through experimentation).

Prepare the Plate for Scanning

Wearing gloves, remove the enveloped PSP from the patient's mouth. Disinfect the Barrier Envelope (with plate still inside) and your gloves by washing with disinfectant hand soap and water. Dry the Barrier Envelope thoroughly. Remove your gloves and wash any powder from your hands. Powder on a PSP will degrade the image, and an accumulation of powder in the scanner will lead to degradation of scanner performance.

INTRAORAL IMAGING

Prepare the Plate for Scanning (continued)

Open the Plate Transfer Box with the lid away from you. Then, remove the exposed PSP from its washed and dried envelope as follows:

Hold the enveloped exposed PSP, with the printed side facing up, parallel to and about an inch above the open Plate Transfer Box. Tear the envelope lengthwise starting at the notch to eject the PSP into the open Transfer Box. Be sure that the sensitive side of the PSP is facing down when it lands (See Figure 4). If it is not sensitive side down, TURN IT OVER IMMEDIATELY. Failure to do so may result in erasure of the PSP.



Figure 4
Ejecting a Plate into the
Plate Transfer Box

SCANNING INTRAORAL PLATES

Configure the Intraoral Plate Guides

If the desired Plate Guides are not in place, install these Guides at this time. Do not operate the scanner without a full complement of four Guides in place. Any combination of Guides may be used. See Figure 5.



Figure 5
ScanX with a full complement of Plate Guides in place.

Activate Scanner

Turn ON the power to the monitor and the computer. Turn ON the power to the scanner by pressing the membrane switch on the front of the scanner. Use your Imaging Software, approved by Air Techniques, to activate the ScanX and to select the desired image type and resolution.

Process Plates

Carefully open the Plate Transfer Box. Grasp a PSP by long edges between the thumb and index finger of your hand. See Figure 6 below. With printed side facing you, carefully insert the PSP into the corresponding size Plate Guide slot as far as possible. Immediately press the PSP all the way down with the tip of your finger (from position Figure 7 to position Figure 8) until the scanner's transport mechanism takes over and the PSP moves on its own. At this point the track light will turn yellow or red, indicating the slot is in use.



Figure 6
Taking a PSP from the
Plate Transfer Box.



Figure 7
Feeding an Intraoral Plate.



Figure 8
Plate fully inserted.

INTRAORAL IMAGING

When you move the PSP from the Plate Transfer Box to one of the Plate Guide slots, do so quickly and be sure the sensitive side of the plate is facing away from any light source. This ensures minimal erasing effect on the PSP. Moving the plate slowly and exposing it to a light source in the process, will partially erase the stored image.

Another PSP may be fed into the same slot as soon as the track light changes back to green.

The scanned PSP will drop into the receiving tray at the bottom of the scanner. When retrieving the PSP, exercise care in handling so as not to scratch the sensitive surface or nick the edges. The PSP may then be erased and processed for reuse.

View and store the image using your Air Techniques Authorized Imaging Software.

POWERING DOWN THE SYSTEM

The ScanX is designed to be left on continuously during the active day. At the end of the day, or if desired, power down the system by performing the following procedure:

1. Exit from your Imaging Software in accordance with its instructions prior to placing the ScanX in standby.
2. Set the ScanX in standby by pressing and holding the membrane switch () in the front of the scanner for approximately two seconds, until the green LED above the switch button extinguishes.

MAINTENANCE PROCEDURES

Maintenance Procedures

The ScanX is designed for many years of trouble-free operation. Maintenance as described herein is minimal.

Cleaning and Disinfecting the System

Turn off the ScanX and disconnect the power cord from the Mains wall outlet before cleaning. Wipe the outside surfaces with a soft paper towel dampened with a disinfectant solution or non-abrasive household cleaner. **DO NOT SPRAY SOLVENTS OR LIQUID DIRECTLY ON THE SCANNER.** Be careful not to allow solvents TO RUN OR DRIP into the ScanX. This could cause damage to the ScanX. Allow to air dry before plugging in or turning back on.

Cleaning Phosphor Storage Plates

Imaging Plates should be handled carefully. For the best images, take care not to scratch the plates. Keep them dust-free. Use the following procedure to clean Plates:

1. Use lint-free, 100% cotton gauze (not cotton balls). Gently wipe the cotton gauze over the dry Plate surface. Wipe back and forth and then in a circular motion.
2. To clean any remaining stains, dampen the gauze in anhydrous ethanol or anhydrous isopropyl alcohol and wipe using the same motion as above.
3. Completely dry the surface by wiping with another piece of cotton gauze. Ensure that the PSP is completely dry before use.

Disinfecting the Phosphor Storage Plates

There is no reason to routinely disinfect the PSP's or Plate Guides unless you believe they have been contaminated. If a PSP has touched a contaminated surface, it may be immersed briefly in a cold sterilant according to sterilant manufacturers directions. **DO NOT SOAK OVERNIGHT.** A 2% Gluteraldehyde solutions will not damage the PSP. After disinfection, clean the Plate and dry with a dust free cloth. If there is any evidence of deep scratches in the surface of the plate or nicks in the edges of the plate, do not immerse the plate.

Cleaning the Plate Guides

Wash the guides with soap and water and dry thoroughly. Use a non-abrasive cleaner. Plate Guides must not be autoclaved.

Disposal of Phosphor Storage Plates

Consult with your federal, national, state and local government, for rules and regulations on disposal of Phosphor Storage Plates.

TROUBLESHOOTING

Trouble	Possible Cause	Corrective Action
No power/ No green light on membrane switch	Instrument not plugged in	Check the line cord connection at each interface to ensure it is firmly plugged in.
	Outlet does not have power	Ensure that the outlet is grounded and has power.
	Main power switch or power supply is bad	Call your authorized Air Techniques dealer.
Green, Yellow or Red indicator light does not work	Defective light	Call your authorized Air Techniques dealer.
Your Image Management Software does not recognize the scanner when the ScanX is selected	Inadequate Computer System	Verify Computer System requirements (Pg. 7).
	The scanner has not been turned on	If the green power indicator light is off, switch ON the ScanX.
	The cable between the ScanX and the computer is loose or defective	Reconnect the cable. Check for tightness.
	The computer does not recognize that the ScanX is connected	Call your authorized Air Techniques dealer.
	There is a hardware problem with the ScanX	Call your authorized Air Techniques dealer.
Plate does not scan properly	The PSP was not pushed far enough into the Plate Guide	Fully feed the PSP into the Plate Guide.
After scanning no image appears	The PSP is fed in backwards (printed side towards ScanX)	Quickly refeed the plate with the printed side out. If a substandard image results, the image must be retaken.
	The PSP was erased prior to scanning	Ensure the PSP's are fed into the scanner immediately and quickly after they are removed from the Plate Transfer Box or the cassette.
	Hardware failure	Call your authorized Air Techniques dealer.
	X-ray source failed	Call your x-ray service dealer.
Image is too dark	PSP has been overexposed	Adjust brightness with software. If this is not possible, feed PSP again, or retake image with proper (lower) exposure.
Intraoral image appears skewed on monitor	PSP was fed skewed either behind a Plate Guide, or without a Plate Guide in place, or	Ensure that Plate Guide is in place and PSP is fed into slot in Plate Guide, or if a Size 4 PSP, PSP is fed in straight behind a Guide.
	Plate Guide used was not the proper size (slot larger than PSP)	Check PSP size and ensure that the correct Plate Guide is in place.
Extraoral image appears skewed on monitor	PSP was fed skewed	When inserting PSP into feed slot, be sure to "feel" for resistance of light seal brush, align PSP, and then push down uniformly on top edge of PSP.

TROUBLESHOOTING

Trouble	Possible Cause	Corrective Action
Image contains ghost images or shadows	PSP was not completely erased.	If using anything but an A/T ScanX Eraser, increase the amount of time that is used to erase plates. Alternatively, increase the intensity of the light source. To test if a PSP is completely erased, scan it. If no image is obtained, your procedure was effective. If using an A/T ScanX Eraser, check proper functioning of the Eraser. Refer to the A/T ScanX Eraser Operator's Manual.
	Imaging Plate was exposed with the back of the IP facing the tubehead.	Ensure the Imaging Plates are inserted properly into the barrier envelope or cassette, and the proper orientation to the x-ray source is maintained.
	PSP has been stored in barrier envelope or cassette for too long.	Do not store PSP's in barrier envelopes or cassettes for more than 24 hours.
	Partial erasure of the image due to exposure to light during handling of the PSP	Do not leave exposed PSP's in well lit areas. Even in the barrier envelope, some light may penetrate and partially erase the PSP. Transfer PSP's from their protective barriers to the ScanX as soon as possible, within one hour of exposure.
Image shows artifacts	The PSP surface is not clean and has dirt, stains or scratches on it	Clean the PSP. If the PSP is scratched or stained, do not reuse.
Intraoral PSP does not drop into the receiving tray	PSP may have clung to the bottom of transport arch due to static electricity.	Look below transport arch and gently touch the PSP to allow it to drop.

IF YOU NEED ASSISTANCE

For additional information, please contact your authorized Air Techniques Dealer or visit our website at www.airtechniques.com

NOTES:

Air Techniques and ALLPRO Imaging are leading manufacturers of fine dental, medical and veterinary equipment from air and vacuum systems and X-ray film processors, to an impressive line of new products incorporating the most recent technological advances. These new products, vital components of the innovative professional practice, include intraoral cameras, digital imaging systems, which utilizes phosphor plate technology and, most recently, an intraoral digital X-ray system using sensor technology.

Air Techniques and ALLPRO Imaging have been manufacturing quality products for the dental, medical and veterinary professional since 1962.

Air Techniques and ALLPRO Imaging products are distributed only through authorized dealers. Refer to www.airtechniques.com or www.allproimaging.com to find a dealer in your area.

- Accent™ Intraoral Digital X-ray Image System
- Acclaim® Intraoral Digital Video Camera System
- Acclaim® USB Only Intraoral Digital Video Camera System
- AirStar®
- A/T 2000® XR
- Guardian™ Amalgam Collector
- Peri-Pro®
- Provecta 70™
- Rinsendo Root Canal Disinfection System
- ScanX®
- STS™
- VacStar™



1-800-AIR-TECH
(1-800-247-8324)
www.airtechniques.com

- 100 Plus
- 2010
- Medscope
- Provecta V
- ScanX® 12
- ScanX® DVM
- ScanX® NDT
- ScanX® 12 EV
- ScanX® 14 Portable
- ScanX® NDT Portable
- ScanX® 14 In-Counter



1-800-AIR-TECH
(1-800-247-8324)
www.allproimaging.com